



Air Purifier and Sterilizer

Hexio

USER GUIDE AND INSTRUCTIONS



Sales & Design: Radic8 Ltd

Man & Scythe, 6 - 8 Churchgate Bolton, BL1 1HL

Tel : +44 (0)1204 238823, E-mail: info@radic8.com,
www.radic8.com

Manufacturer: INBair Co., Ltd

3F, 15, Beotkkot-ro 12-gil, Geumcheon-gu, Seoul, Korea
Tel: +82-31-811-1000, E-mail: inbair01@naver.com,
www.inbair.com

Made in Korea, Designed in England

Table of Contents

Important Safety Instructions.....	1
Operation Instructions	4
What's Included and Optional Parts.....	5
Key Parts and Components.....	6
Hexxio Functions.....	7
Filter Cleaning and Replacement.....	11
How to Replace the Reactor Cell.....	12
How to Maintain and Clean the IAQ Sensor.....	14
How to Replace the Fragrance Filter.....	15
Troubleshooting.....	16
Customer Services.....	18
Specifications.....	19
Limited Warranty Card	

Important Safety Instructions

The following instructions are provided to ensure your safety and to protect the unit from accidental damage.



- **Read these instructions** – All the safety and operating instructions should be read before this product is operated.
- **Keep these instructions** – The safety and operating instructions should be retained for future reference.
- **Heed all warnings** – All warnings on the appliance and in the operating instructions should be adhered to.
- **Follow all instructions** – All instructions for use and operation should be followed.
- **Warranty** – included inside.

Warning – This symbol indicates important safety instructions that must be followed to avoid injury.

Caution – This symbol is to bring important information to your attention to avoid the risk of injury or damage to the unit.

Prohibited – This symbol indicates a forbidden action. Adhere to these to reduce the risk of injury or damage to the unit.

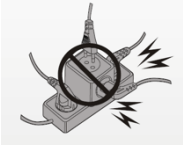
Electrical Safety

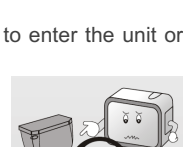
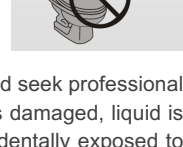
- The unit should only be connected to a main power supply with voltage that matches that specified.
- To prevent overload, do not share the same power supply socket with too many other electronic components. 
- Do not place the power cord where it could be stepped on or tripped over. 
- Do not place heavy items on the power cord, they could damage the wire. 
- Do not allow water or moisture to enter the unit or power adapter. 
- Do not use in wet, moist areas such as bathrooms, steamy kitchens or near swimming pools.
- Pull the plug out immediately and seek professional help if the plug or power cord is damaged, liquid is spilled onto the unit, if it is accidentally exposed to moisture or the unit is not working normally.



! Operation Safety

- Keep the product away from flammable gases and liquids, candles and open flames.
- Do not install near any heat sources such as radiators, stoves, or other apparatus that produce heat.

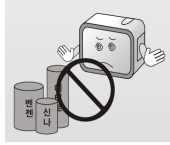

- Do not attempt to repair or replace any part of this equipment unless it is specifically recommended in the user guide. All other services should be referred to a qualified technician.



- Make sure the power cord is plugged firmly and completely into the outlet.
- Hold the main plug, not the wires, when removing from a socket.
- During a thunderstorm switch off the unit and unplug from the socket.
- Do not handle the unit with wet hands.
- Only clean with a soft, dry cloth. Do not use solvents or petroleum based fluids.



- Do not place heavy objects on the unit.
- Do not shake, knock or move the product while in operation, you may damage the internal circuits.



! Operation Instructions

- **Do not use while cleaning the room**

After cleaning, it is important to properly ventilate the room before using Hextio.



- **Not to be used while cooking**

Oils released while cooking may reduce the lifespan of the sterilizing module. After cooking, the room should be ventilated to remove oils. Hextio can then be used to remove the remaining smell.



- **Ensure airflow is not restricted**

Do not position Hextio so that airflow to and from the unit is restricted by large items such as furniture, electronic items or curtains.

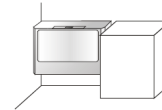

- **Maintain proper ventilation**

Hextio is designed to purify and sterilize your indoor air, and will do this very effectively if used correctly. Good indoor air quality also requires proper ventilation. We recommend opening windows or doors, or operating A/C units, for at least 30 minutes a day.

! Caution

- The appliance is not to be used by children or persons with reduced physical, sensory or mental capabilities. This appliance is not a toy. Children should be supervised at all times.
- Never look directly at a burning ultra-violet light – this may permanently damage your eyes. Switch off and unplug before performing maintenance.

What's Included and Optional Parts



Body and Accessory

1. Main Body
2. Bracket for Wall Mounting
3. Remote Control
4. Basket for Remote Control
5. Packet of 2 Carbon Filters
6. DC 12V Adapter
7. User Guide and Sticker

Optional Parts

8. Extra Reactor Cell
9. Fragrance Filter Case
10. Fragrance Filter

Key Parts and Components

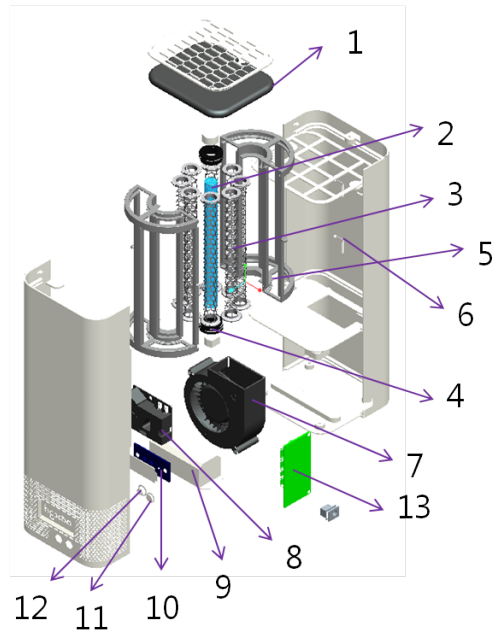

1. Carbon Filter
2. UVC Lamp
3. Hexagon TiO₂ Filter
4. Rubber Holder
5. Reactor Tray
6. Mirrored Chamber
7. BLDC Sirocco Fan
8. Dust/Germ/VOC Sensor
9. UVC Ballast
10. Logo LED
11. Remote Control Sensor
12. Power Switch
13. Control Board

Hextio Functions

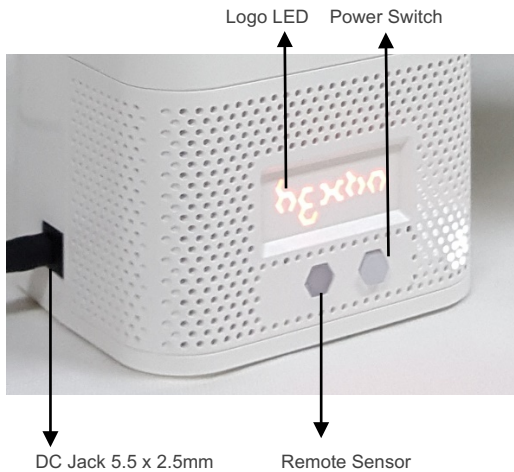

Display and Alarm – the Logo LED functions

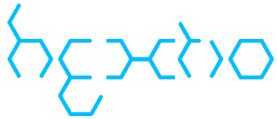

The mode is indicated by the color of the Logo LED as follows:

1. **Blue** – automatic mode. Indicates good air quality and normal fan speed of 20%
2. **Red** – automatic mode. Indicates poor air quality and high fan speed of 100%
3. **Green** – manual mode. Fan power can be set to 3 speeds; low 20%, medium 50%, or high 100%
4. **Red, flashing continuously** – indicates reactor cell replacement is due.

Remote Control

Automatic Operation Mode:

When the unit is switched on, either by the power switch on body or the on/off button on the remote control, the product is in automatic mode. Blue LED lights are displayed and the fan speed is normal (20%). If dust, germs or VOC's are detected by the sensor, the fan switches to full power and red LED lights are displayed. When the dust, germ or VOC levels return to healthy levels, the unit automatically returns to 20% fan speed and displays the blue color.

Note - When the unit is switched on the Indoor Air Quality (IAQ) sensor takes up to 5 minutes to calibrate.

Press “on/off” button.

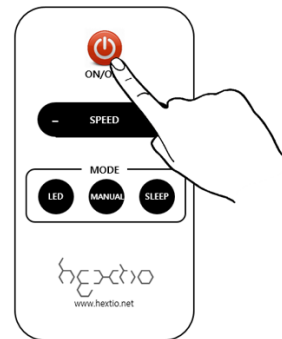

Manual Operation Mode:

If you wish to manually control the fan speed, press the manual button on the remote control. The green LED light is displayed to indicate manual mode. Press “speed” “+” or “-” to change the fan speed. The settings are low 20%, medium 50% and high 100%.

Press "MANUAL" button.

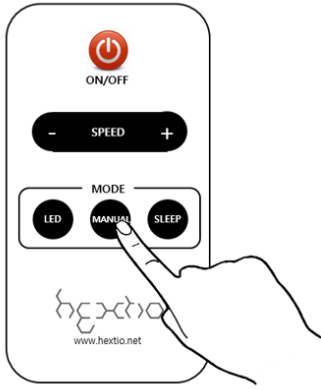

Press "SPEED" "+" or "-" button".

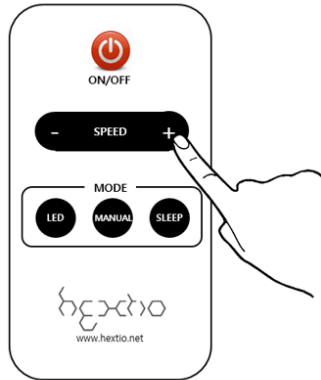

Sleep Mode:

When sleep button is pressed, the fan switches to very low (10%) and all LED lights are switched off.

Press "SLEEP" button.

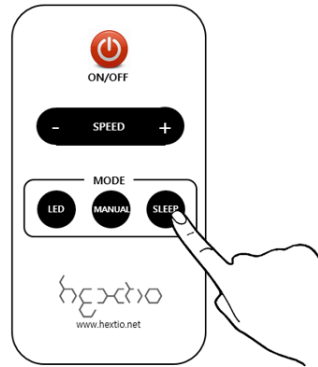

Indirect LED Light

In addition to the Logo LED, there are also indirect LED lights inside Hextio. When the LED button is pressed, the indirect LEDs are switched off or on.

Press "LED" button.

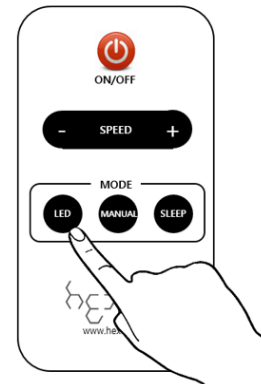

Filter Cleaning and Replacement

The TiO₂ Carbon Filter



One side of the carbon filter is coated with TiO₂ (titanium dioxide) to increase the photo catalytic power of Hextio. This side (shown on the right) is pale grey / silver and should be placed face down. The black side should face up, as shown below.



Caution:

- Switch off and unplug the unit before performing maintenance.
- Never look directly at a burning ultra-violet light.

It is good practice to check the carbon filter once per month and clean it using a vacuum cleaner if necessary. The carbon filter should be changed every 6 months at least. Simply unscrew the two screws on top of the grill to remove and replace the filter.

How to Replace the Reactor Cell

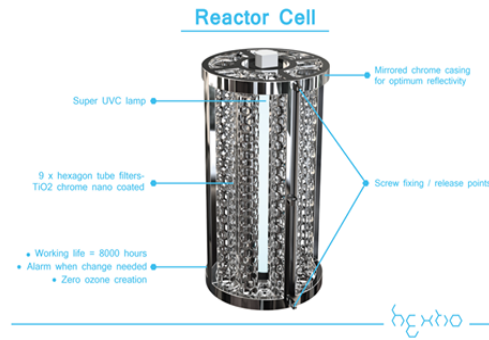

The Reactor Cell should be replaced when the usage time has reached a total of 8000 hours. Hextio will indicate this is due by displaying red flashing Logo LED lights.



Caution:

- Switch off and unplug the unit before performing maintenance.
- Never look directly at a burning ultra-violet light.

Procedure to Replace Reactor Cell:

1. Open filter case and loosen 2 screws at top.



2. Detach 4 rubber feet and loosen 4 screws.



3. Open the body and loosen 4 screws surrounding Reactor Cell.

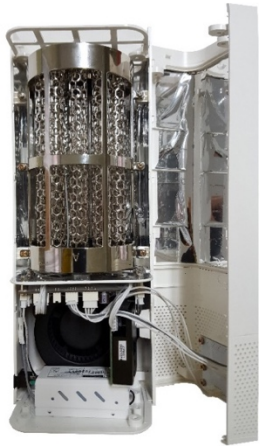

4. Detach wire connector.

5. Replace with new reactor cell and assemble in reverse order. The used reactor cell is fully recyclable, as a consumer it is your responsibility to ensure it is disposed of properly.

Important:

After replacing reactor cell, press and hold the power button on the body for 10 seconds. This resets the operation time to zero.

How to Maintain and Clean the IAQ Sensor

The IAQ sensor is a very delicate instrument that uses light scattering to detect pollution. It therefore needs a clean lens to work effectively. Regular maintenance (every 6 months) should be carried out to keep the lens clean.

Important – Only use pure water and allow to dry completely before replacing. To avoid damage to the plastic lens do not use chemicals such as benzene or alcohol (found in some cleaning products).

Procedure to maintain and clean the IAQ Sensor:

1. Open the body as shown in the previous image.
2. Detach wire connector attached to IAQ sensor.
3. Clean lens with a clean cotton swab dampened with pure water.

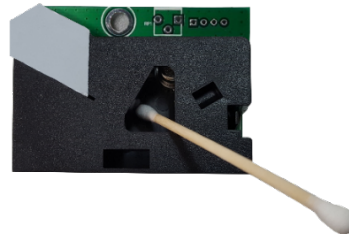

4. Dry lens and IAQ sensor.
5. Assemble in reverse order.

Caution:

- Do not place in direct sunlight.
- Do not spray water or perfume near the sensor.



How to Replace the Fragrance Filter

To open the Fragrance Filter case, grip the lid and pull firmly. You may need to inset a thin object between the base and lid to release the inner hooks. Please take care if using a knife. Replace fragrance pouch, click lid and base back together and simply place on top of Hextio body.



Caution:

- The Fragrance Filter is designed for use with dried natural flowers, herbs and whole spices, or fragrance liquids / essential oils. Herbs, spices or flowers should always be contained within a pouch or bag, and oils must be transferred onto a felt pad.
- If using oils, it is important not to over saturate the felt pad. 2 ml is the maximum recommended amount. Exceeding this amount may cause oil to drip down into the unit and damage it.

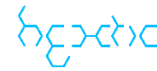

Troubleshooting

Before you call for service, review this list. It may save you time and expense. This list includes common occurrences that are not the result of defect in workmanship or materials.

Problem – Product will not turn on.

Possible Cause

Is power cord correctly connected to outlet?

Solution

Ensure power cord is properly inserted into Hextio and socket.

Possible Cause

Check remote controller?

Solution

Change / reinstall batteries correctly according to the polarity.

Possible Cause

Check if the voltage of DC adaptor is too low?

Solution

This product should be used with a DC 12V 1.5A adaptor.

Problem – Weak wind volume or noise from the product.

Possible Cause

Check if dust has accumulated in the filter?

Solution

Filter should be replaced at the appropriate time, (approximately every 6 months) and cleaned regularly.

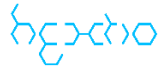

Problem – The air purifying function does not work well

Possible Cause

Check if indoor air is seriously contaminated?

Solution

Ventilate properly, minimum 30 minutes.

Possible Cause

Check if airflow is restricted?

Solution

Make sure there is sufficient clearance around the product and that the air inlet and outlet are not blocked by furniture, curtains etc.

Problem – Strange smell is emitted from the air outlet.

Possible cause

Is this a 'new product' smell?

Solution

It may be an antimicrobial smell emitted by the sterilizing module or filters and will disappear over a short period of operation (1-2 weeks). It is completely harmless to humans and animals.

Possible cause

Has the unit been used during or shortly after cooking?

Solution

Food odors can permeate into the filter or the sterilizing module. Use only after sufficient ventilation.

Possible cause

Has the unit been used where there are heavy emissions of smoke or odors?

Solution

In areas emitting smoke or odors, the performance of the sterilizing module may be affected. Use only after ventilation.

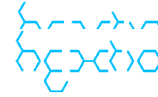

Customer Services

In this manual, you will find a card containing details of your limited warranty and contact details for your local customer services center, to whom all enquiries and warranty claims should be directed.

All warranties are rendered void and the cost of repair will be payable by the user in the case of:

1. Damages caused by putting foreign objects (such as water, soft drink, coffee, fragrance oils or toy etc.) in or on the unit.
2. Damages caused by transportation or handling.
3. Damages caused by use of products such as benzene or thinner.
4. Damages caused by incorrect power supply.
5. Breakdown or loss of parts caused by unauthorized disassembling or modification.
6. Repair or replacement undertaken by unauthorized persons.
7. Damages caused by non-adherence to the instructions provided in this user guide, and as given by the local customer service center.
8. Damages caused by careless or improper use.
9. Damages caused by operating the product in a corrosive or moist environment.

Specifications



Radic8 reserves the right to make changes to the exterior, design or specifications of the product without prior notice.

Description	Air purifier
Brand	Hexio
Model No	HX-100
Elec. Power	DC 12V 1.5A
Elec. Consumption	15 watt
Net Weight	1.2 Kg
Gross Weight	1.8 Kg
Net Dimension	330 x 124 x 105mm
Box Dimension	396 x 195 x 158mm